



***STAGE IV<sup>®</sup> - 2000***

***STAGE IV – 3000***

***STAGE IV – 3000 Plus***

**Pressure  
Relieving Systems**

**Operating Instructions**

**SenTech Medical Systems**

Revision: AO-SM3000-01

 **WARNING**

Before operating this medical equipment, it is important to read this manual and to understand the operating instructions and safety precautions.

Failure to do this could result in patient injury and/ or damage to the product. If you have any questions, please contact SenTech Medical Customer Service at **800-474-4225** or **954-340-0500**.

# **Table of Contents**

	<u>Page</u>
<b>1.0 Safety Precautions</b>	<b>4</b>
<b>2.0 Product Overview</b>	<b>6</b>
<b>3.0 Installation</b>	<b>7</b>
<b>4.0 Operation</b>	<b>9</b>
<b>5.0 Maintenance And Cleaning</b>	<b>18</b>
<b>6.0 Troubleshooting Guide</b>	<b>21</b>
<b>7.0 Product Specifications</b>	<b>24</b>
<b>8.0 Warranty Information</b>	<b>26</b>
<b>9.0 Product Return</b>	<b>27</b>

## 1.0 SAFETY PRECAUTIONS –

**CAUTION!** Certain medical conditions and treatments are **contraindicated** for use of the STAGE IV 2000, STAGE IV 3000 & STAGE IV 3000 PLUS Systems (“STAGE IV SYSTEMS”). **Always consult with the patient’s physician before placing a patient on an Alternating Pressure system.**

**CAUTION!** Bed frames used with the STAGE IV SYSTEMS can vary greatly depending on the specific health care setting, e.g., hospitals, nursing homes, home care, etc. Therefore, it is the responsibility of the caregiver to take the necessary precautions to ensure the safety of the patient. This includes, but is not limited to, the appropriate use of side rails to prevent falls and/or patient entrapment.

### Electronic Controller –

#### **DANGER!**

- Do not use in the presence of flammable anesthetics. **Risk of explosion can result.**
- Only plug into a grounded “hospital grade” power receptacle and use the power cord supplied with the STAGE IV SYSTEMS.
- Exposure of the electronic controller to any liquid while it is plugged in could result in a severe electrical hazard.
- Only use fuses that have the same specified rating (**See Section 7.0 Product Specifications**). Using fuses with higher ratings could result in damage and/or injury.

#### **CAUTION!**

- The 120 VAC, 60 Hz models of the STAGE IV SYSTEMS incorporate fusing only in the ungrounded phase conductor. **These products must not be used in countries other than the United States or Canada.** They must be used in health facilities on grounded systems where conditions of maintenance and supervision ensure that only qualified persons will service the electrical distribution system.
- The STAGE IV 2000, STAGE IV 3000 & STAGE IV 3000 PLUS are separate systems. Do not interchange electronic controllers and mattresses.
- The electronic controller is a precision electronic product. Use care when handling or transporting. Dropping, or other sudden impacts, may result in damage to the controller.

#### **CAUTION!**

- Risk of Electric Shock. **DO NOT OPEN.** Do not attempt to repair or service the electronic controller. Repairs and service should only be done by SenTech Medical Systems. If the controller is not functioning properly, or has been damaged, unplug the unit and take it out of service immediately. Contact Customer Service at **800-474-4225** or **954-340-0500** for repair and service information.

## Electronic Controller (Continued) –

### **IMPORTANT!**

- Do not return a product for any reason without first contacting Customer Service to obtain return authorization (**See Section 9.0**).
- Do not place any objects/items, such as blankets, on, or over, the electronic controller. Excessive weight on the controllers could result in damage to the electronic controller.
- After exposure to extreme high or low temperatures, allow electronic controller to equilibrate to room temperature before operating.
- The controllers circulate room air during operation. Exposure to smoke may cause the system to fail. Therefore, smoking by patients, or visitors, while using the STAGE IV SYSTEMS is strongly discouraged.
- The power cord to the electronic controller should be positioned to avoid a tripping hazard and/or damage to the cord. SenTech recommends placing the cord under the bed frame and attaching it to an electrical outlet by the head of the bed.

## 2.0 PRODUCT OVERVIEW

The STAGE IV SYSTEMS are microprocessor controlled **Alternating Pressure Relief** and **Low Air Loss** therapeutic mattress systems. The needs of individual patients can be optimized by combining these therapies or operating them independently from each other.

The Alternating Pressure feature of the STAGE IV SYSTEMS provide pressure relief by deflating and inflating every other air cell on a timed interval. It is widely recognized that constant pressure to a bony prominence is a leading cause of skin breakdown. The STAGE IV SYSTEMS provide continuous movement of air cells that alleviates constant pressure and enhances circulation. The deflated air cells provide pressure relief, while the inflated air cells support the patient's weight.

The STAGE IV electronic controllers provide a real-time display of air pressure for both the inflated and deflated air cells. The amount of pressure to support a patient can be set automatically based on the patient's height and weight or can be manually set for custom configurations. All settings are stored in non-volatile memory. If power is interrupted, the electronic controller automatically returns to the previous settings when the power returns.

The Controlled Low Air Loss (LAL) feature of the STAGE IV SYSTEMS provide an optimum temperature environment to assist in patient healing and comfort. LAL therapy is delivered through a patented SenTech Coverlet that provides a flow of diffused air directly to the patients skin through thousands of microscopic micro-vents. In addition, the mattress has been designed to provide an anti-shear/anti-friction surface for patients.

The STAGE IV 3000 PLUS accommodates bariatric patients weighing up to 990 pounds. The STAGE IV 3000 PLUS is similar in operation to the STAGE IV 3000, except for the increased weight capacity. Operating Instructions are the same except as noted.

## 3.0 INSTALLATION –

**NOTE:** It is recommended that all shipping and packing material be saved in the event that the product has to be sent back to SenTech Medical.

### 3.1 Unpacking and Inspection -

Carefully remove the controller, mattress and all accessories from the shipping cartons. Inspect all items for any damage that may have occurred during shipping. Any damages, or missing components, should be reported to SenTech Customer Service as soon as possible.

**Mattress Replacement:** The box contains a completely assembled mattress replacement system. This system consists of:

- 1.5 Inch Foam Mattress
- Air Cell Assembly with CPR Pull
- Top Coverlet with Low Air Loss Hose
- CPR Hose Assembly (Hospital Grade Only)

**Electronic Controller:** The electronic controller is in a separate box containing:

- Electronic controller
- Power cord
- Operating Instructions

### 3.2 Installation Requirements –

STAGE IV SYSTEMS are designed to operate in a controlled environment, which is free from extreme temperatures, high humidity and/or excessive amounts of airborne particulates, such as dust and smoke. The controller can be plugged into any standard wall outlet and hung on the upper outside edge of the footboard on most hospital and home care beds.

### 3.3 Installation of Air Mattress:

**Mattress Replacement System:** No assembly is required.

Remove the current mattress from the bed frame and replace with the STAGE IV Mattress assembly. The hose connections should be positioned at the bottom left of the bed.

There are two (2) sets of straps with D-rings on each side and one (1) at the head of the mattress. Use these straps to secure the mattress replacement to the bed frame.

**IMPORTANT:** Make sure that the attachment of the mattress does not interfere with bed movement/operation.

### 3.0 INSTALLATION (Continued) –

#### 3.4 Installation of CPR Pull –

1. For Hospital Grade systems, the CPR assembly is permanently attached to the mattress and no installation is required. However, it is important to ensure that the CPR is in the “CLOSED” position before inflating the mattress (See **Sections 4.4.2- 4.4.4**).
2. For standard STAGE IV 2000/3000 systems, the CPR is located at the *head* of the mattress and has already been installed at the factory. Although, no further installation is required, the CPR should be inspected to ensure that it has not loosened or disconnected during shipping.

#### 3.5 Installation of Electronic Controller -

1. Hang the STAGE IV SYSTEM controller over the footboard of the bedframe.
2. **Coverlet Hose:** Connect the single Low Air Loss hose from the center of the coverlet to the connector on the right side of the controller labeled “Low Air Loss”.  
**Mattress Hoses:** Connect the hoses from the left side of the mattress shell to the connectors on the left side of the electronic controller:
  - STAGE IV 2000 – Two (2) hoses connected in any order.
  - STAGE IV 3000/3000 PLUS - Six (6) color-coded hoses connected to the corresponding color-coded connectors on the left side of the controller i.e., red to red, green to green, etc.

**NOTE: Each connector should tightly “click” into place.**

3. Plug into electrical outlet. Turn the POWER on with the power switch located next to the electrical cord, on the right side panel of the controller.
4. Inflate the mattress by pressing the blue MAX INFLATE key on the touch panel. In this mode all mattress cells are inflated to 40 mmHg (60 mmHg for STAGE IV 3000 PLUS) to provide a firm, flat surface. The MAX INFLATE mode will last for 20 minutes, unless it is interrupted by pressing any other function key. The system will then automatically revert back to the previous operating mode.



## 4.0 OPERATION –

The control panels for the STAGE IV 2000, STAGE IV 3000 and STAGE IV 3000 PLUS electronic controllers are shown in the diagrams below. Refer to these diagrams as you read the OPERATION section.

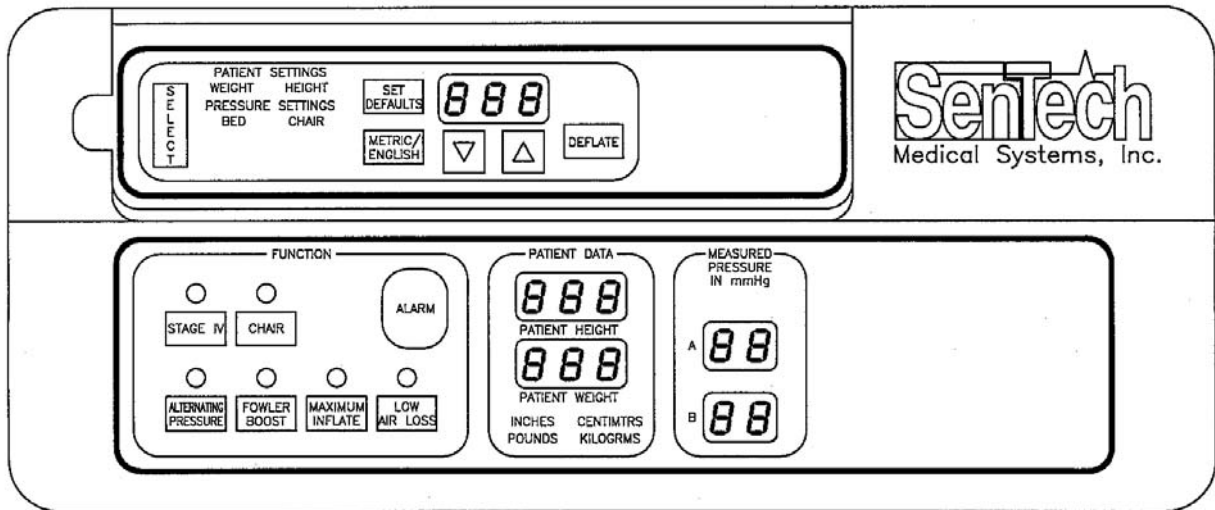

**STAGE IV 2000 CONTROL PANEL**

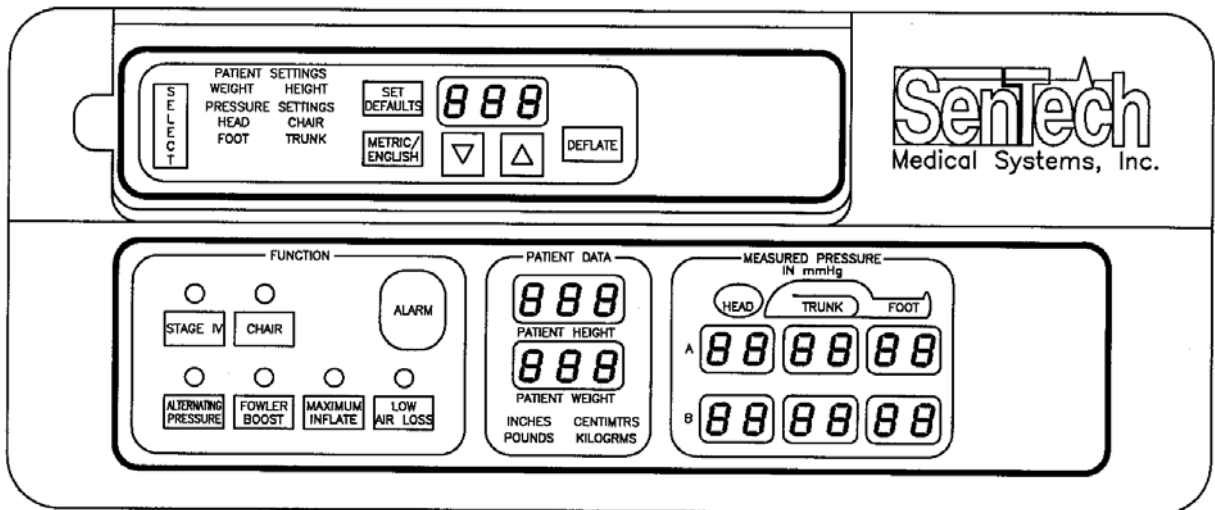

**STAGE IV 3000 and 3000 PLUS  
CONTROL PANEL**

## 4.1 Functions and Settings –

Many of the functions and settings on the STAGE IV SYSTEMS are the same. Where differences are present, they will be noted.

**Power** The ON/OFF switch is located next to the electrical cord on the right side of the controller. The switch will illuminate in the “ON” position

**FUNCTIONS:** The following controls are located on the front display panel:

**Stage IV** Sets the system to the “BED” operating mode with a 5 minute cycle time when in Alternating Pressure.

**Chair** Sets the system to the “CHAIR” operating mode with a 2.5 minute cycle when in Alternating Pressure.

**Alternating Pressure/Air Floatation** Activates/Deactivates Alternating Pressure Relief mode. When activated, the system operates in alternating pressure mode. When deactivated, the system operates in Air Floatation mode.

**Fowler Boost** Activates/Deactivates the Fowler Boost feature. When activated, the set pressure in the mattress (STAGE IV 2000), or the trunk area (STAGE IV 3000), is automatically increased by 20%. This feature is used for patients in bed that are put in an inclined or “Fowler” position. It is not available when the system is in the MAX INFLATE or CHAIR modes.

**Maximum Inflate** Activates/Deactivates the MAX INFLATE mode. In this mode, all mattress cells are inflated to a pressure of 40 mmHg (60 mmHg for STAGE IV 3000 PLUS) to provide a firm, flat surface. This mode will last for 20 minutes, unless interrupted by the pressing of any function key. The system will then revert back to the pre-set STAGE IV operating mode. When the system is in the chair mode, the Maximum Inflate switch is inactive.

**Low Air Loss** Activates/Deactivates the Low Air Loss (LAL) feature. When activated, a gentle diffused flow of air is delivered through the LAL coverlet. This feature is not available when the system is in CHAIR mode.

**SETTINGS:** The following settings are located under the black cover on the top portion of the control panel:

**Select** Scrolls through the various setting fields. The active field is displayed in the update window and the appropriate indicator is illuminated. The table below shows the selection options available:

	<u><b>PATIENT</b></u>	<u><b>PRESSURE</b></u>
<b>STAGE IV 2000</b>	WEIGHT HEIGHT	BED CHAIR
<b>STAGE IV 3000 &amp; STAGE IV 3000 PLUS</b>	WEIGHT HEIGHT	HEAD TRUNK FOOT CHAIR

**UP/DOWN Arrow Keys** Used to increase or decrease the patient data or pressure settings.

**Auto Set** Automatically adjusts the pressure settings based on the patient weight and height entered. Selecting “Auto Set” will override custom set pressures.

**Note: Changing the patient data does not automatically update the pressure settings. Auto Set must be pressed to incorporate the change.**

**Metric/English** Toggles the units of measurement used for the patient weight and height between English (inches & pounds) and Metric (centimeters and kilograms).

**Deflate** Allows air to be pumped out of the mattress automatically. After ten (10) minutes, the pump automatically shuts off. During deflation, all displays and indicators, except the deflate indicator, will be shut off. If this key is pressed in error, press the key again to deactivate and the system will revert to it’s previously programmed state.

#### 4.2 Indicators -

**Alarm** Located on the display panel and will illuminate and audibly sound when the mattress fails to reach the set pressure for three consecutive cycles, approximately 30 minutes.

**Inches / Pounds** Illuminates when the patient data is displayed in English units of measurement.

<b>CM / KG</b>	Illuminates when the patient data is displayed in Metric units of measurement.
<b>Patient Data</b>	Displays patient height and weight as entered in the “Patient Data”. This data is used by the microprocessor to calculate pressure settings, when AUTO SET is selected.
<b>Measured Pressure</b>	Continuously displays the actual air pressure in mmHg that is delivered to the air cells in the mattress. The STAGE IV 3000/3000PLUS displays the measured pressure in the HEAD, TRUNK and FOOT zones. The STAGE IV 2000 shows measured pressure delivered to the whole mattress. The “A” and “B” on the display panel show the pressure in alternate air cells.

### 4.3 Programming Electronic Controller –

#### Top Portion of Controller:

1. Open the black cover located on top of the controller. Select the preferred units of measurement for patient data by pressing the METRIC/ENGLISH key. You will see your selection lit in the bottom portion of the display under “Patient Data”.
2. Toggle the SELECT key until PATIENT WEIGHT is lit. Using the up and down arrow keys select the appropriate patient weight. Weight is adjusted in 10-pound increments. Round the patient’s weight up to the nearest 10-pound increment.
3. Toggle the SELECT key until PATIENT HEIGHT is lit. Using the UP and DOWN arrow keys select the appropriate patient height.
4. Press AUTO SET. The pressure setting is now automatically set for that patient.

**NOTE:** The AUTO SET setting is not appropriate for all patients. Some patients may require custom settings for optimal therapy. To select a custom setting for the STAGE IV 2000, toggle the SELECT key until BED is displayed and adjust the pressure by using the UP and DOWN arrow keys. To select custom settings for the STAGE IV 3000/ STAGE IV 3000 PLUS, toggle to the HEAD, TRUNK or FOOT and adjust the pressure by using the UP and DOWN arrow keys. After readjusting the pressure setting, DO NOT hit AUTO SET. The pre-programmed pressure settings in the STAGE IV 3000 PLUS electronic controller are intended as “guidelines”. When using the “AUTO-SET” function, caregivers must pay particular attention to ensure that the optimal pressure is provided for each patient.

## Bottom Portion of Controller:

1. From the bottom left area of the display select which therapy and features you wish to operate. Be sure that "STAGE IV" is selected and lit on the control panel while the patient is in bed. The Stage IV SYSTEMS will also operate the *SenTech* Bedside, Recliner and Recliner 550 Air Chairs.

**Caution!** The CHAIR function should only be used with these *SenTech* products.

Operation of the CHAIR function is presented below:

### STAGE IV 2000 & 3000 –

#### Switching from the Mattress to the Air Chair Mode -

1. Turn the controller OFF and unplug the *red* and *white* mattress hoses from the left side of the electronic controller.
2. Connect the two hoses from the Air Chair to the *red* and *white* connectors on the left side of the electronic controller in any sequence.
3. Turn the electronic controller ON and follow Setup of the Air Chair procedure below.

#### Setup of the Air Chair -

1. On the front panel, locate the CHAIR key.
2. Lift the black top cover and locate the SELECT key.
3. While pressing and holding the SELECT key, press the CHAIR key.

**NOTE:** When the CHAIR indicator is illuminated, the CHAIR function is active.

#### Adjusting Pressure Settings -

The Stage IV SYSTEMS will automatically adjust the pressure settings to accommodate the CHAIR Mode. However, pressures can be adjusted for individual patient needs according to the following procedure:

1. Toggle the SELECT key until the word chair is illuminated.
2. Using the UP and DOWN arrows, adjust to the desired pressure.

**IMPORTANT!** After the pressure adjustment is made, DO NOT press the AUTO SET key.

### STAGE IV 3000 PLUS –

The only difference from the above procedure is how the CHAIR Mode is selected. To select the CHAIR Mode, press the CHAIR key on the control panel.

2. Select the therapy desired. The STAGE IV SYSTEMS have the ability to provide **ALTERNATING PRESSURE (AP)** or **AIR FLOATATION (FLOAT)**, and **LOW AIR LOSS (LAL)** therapies:
  - For AP, press the blue ALTERNATING PRESSURE key until it is lit.
  - For FLOAT, turn the Alternating Pressure off by pressing the blue AP key. The alternating pressure light will not appear lit. LAL may be operated simultaneously with AP or FLOAT, or not at all.
  - For Low Air Loss (LAL), press the yellow LOW AIR LOSS key until lit.
3. For patients that are in a Fowler position, i.e., an inclined or sitting position, it is recommended that the FOWLER BOOST be activated by pressing the blue FOWLER BOOST key until lit.
4. Select the MAX INFLATE for a firm surface throughout the entire bed by pressing MAX INFLATE key on the control panel. When MAX INFLATE is selected, it disables all other functions and only LAL will operate.

#### 4.4 CPR Operation –

For emergency situations that require rapid evacuation of the air in the mattress, the STAGE IV SYSTEMS are equipped with CPR pulls:

##### 4.4.1 Standard CPR (STAGE IV 2000 & STAGE IV 3000 Only)-

The CPR Pull is located at the *head* of the mattress on the patient's right side.

1. To activate, firmly pull the red tag labeled "CPR". To increase deflation rate, disconnect the hoses from the controller.
2. All air cells will begin to deflate and air will be rapidly evacuated. Rate of evacuation is dependent on the weight of the patient.
3. To resume normal operation of the mattress, close the CPR device by fully inserting the CPR hoses onto the connector. The Stage IV 2000 SYSTEM has two (2) CPR hoses; the Stage IV 3000 SYSTEM has four (4) hoses.

##### 4.4.2 Hospital Grade CPR (STAGE IV 2000 (Optional), STAGE IV 3000 (Optional) and STAGE IV 3000 PLUS) -

The CPR is located at the foot of the mattress on the patient's right side and is permanently attached to the mattress. The *Low Profile CPR* for STAGE IV 3000 and 3000 PLUS is shown in **Diagram 1** below. The STAGE IV 2000 *Low Profile CPR* operates the same, but only has two (2) hoses.

## DIAGRAM 1 – CLOSED Position

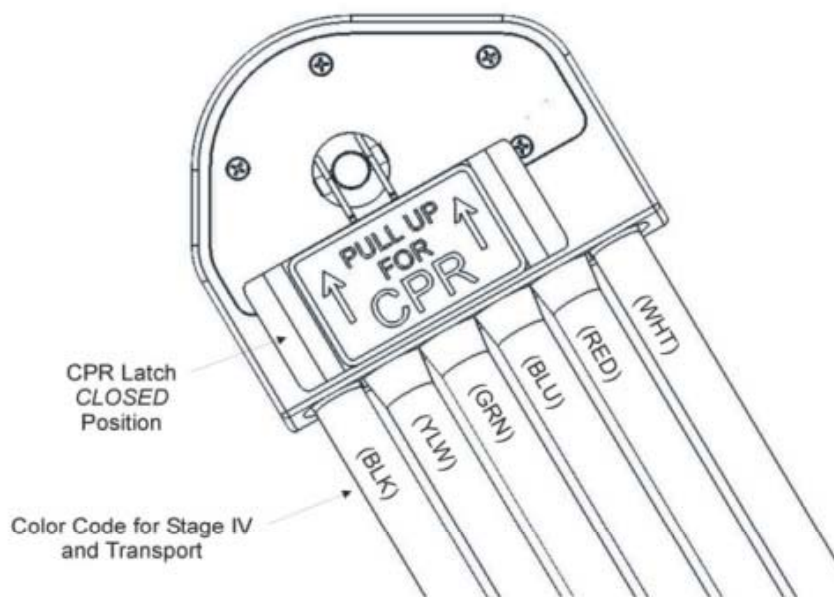

### CAUTION!

- Loose hoses can be a tripping hazard. Use caution when transporting the mattress.
- DO NOT immerse the CPR in any liquids.
- Avoid exposure to high heat and/or solvents.
- Protect hoses from sharp or pointed objects that could cut, puncture or tear the material.
- DO NOT attempt to repair the CPR. If damaged or not working properly, call SenTech Customer Service at **800-474-4225** or **954-340-0500** for service information.

### 4.4.3 Setup & Operation

1. Before operating the system, make sure that the CPR Latch is *completely* down in the CLOSED position (See **Diagram 1**).
2. To activate the CPR and rapidly evacuate the air from the mattress, pull the CPR Latch *completely* up to the OPEN position (See **Diagram 2**). Rate of evacuation is dependent on the weight of the patient.
3. To resume normal operation of the mattress, push the CPR Latch *completely* down to the CLOSED position.

## DIAGRAM 2 – OPEN Position

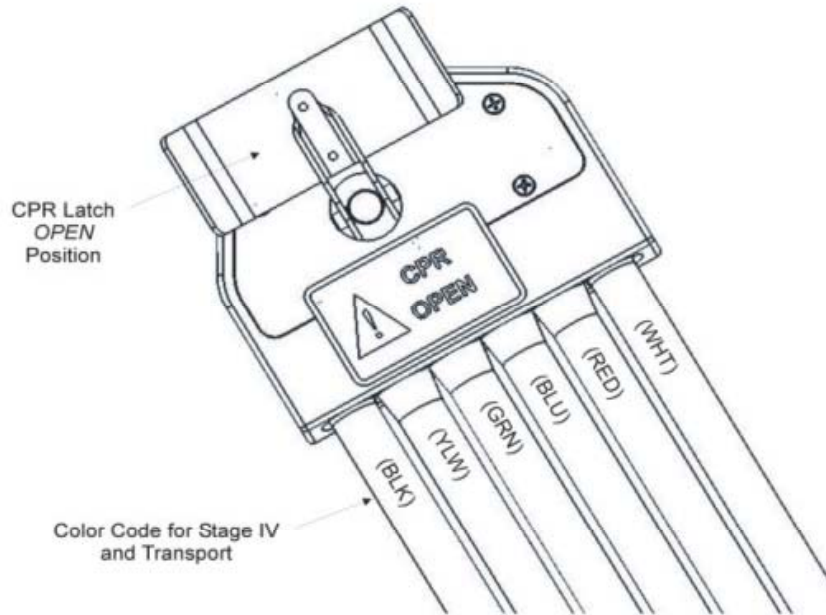

### 4.4.4 CPR Troubleshooting Guide –

Problem	Cause	Solution
1. CPR Leaks.	<ul style="list-style-type: none"> <li>a) CPR Latch is not completely down in the CLOSED position.</li> <li>b) Material between the CPR block and the socket is preventing a proper seal.</li> <li>c) Belleville washers are not properly aligned.</li> <li>d) Screw on brass shaft is not tight.</li> <li>e) O-ring(s) are missing/damaged.</li> </ul>	<ul style="list-style-type: none"> <li>a) Make sure the CPR Latch is <i>completely</i> down in the CLOSED position.</li> <li>b) Make sure that nothing is between the CPR block and the mattress shell that is preventing full closure of the CPR, e.g., sheet/blanket.</li> <li>c) Open CPR latch, loosen screw, align washers onto brass shaft, and retighten screw so that head of screw contacts brass shaft. Close CPR latch.</li> <li>d) Open CPR latch and re-tighten screw. Close CPR latch.</li> <li>e) Contact SenTech Customer Service at <b>800-474-4225</b> or <b>954-340-0500</b> for service information.</li> </ul>
2. CPR loose when latch is in the CLOSED position.	<ul style="list-style-type: none"> <li>a) Screw on brass shaft is not tight.</li> <li>b) CPR components are missing or improperly installed.</li> </ul>	<ul style="list-style-type: none"> <li>a) Tighten screw.</li> <li>b) Refer to <b>Section 4.4.5</b> below.</li> </ul>



#### 4.4.5 CPR REMOVAL/INSTALLATION –

The Low Profile CPR is permanently attached to the mattress and should *not* need to be removed. However, if necessary, it can be removed and reinstalled by following the directions below:

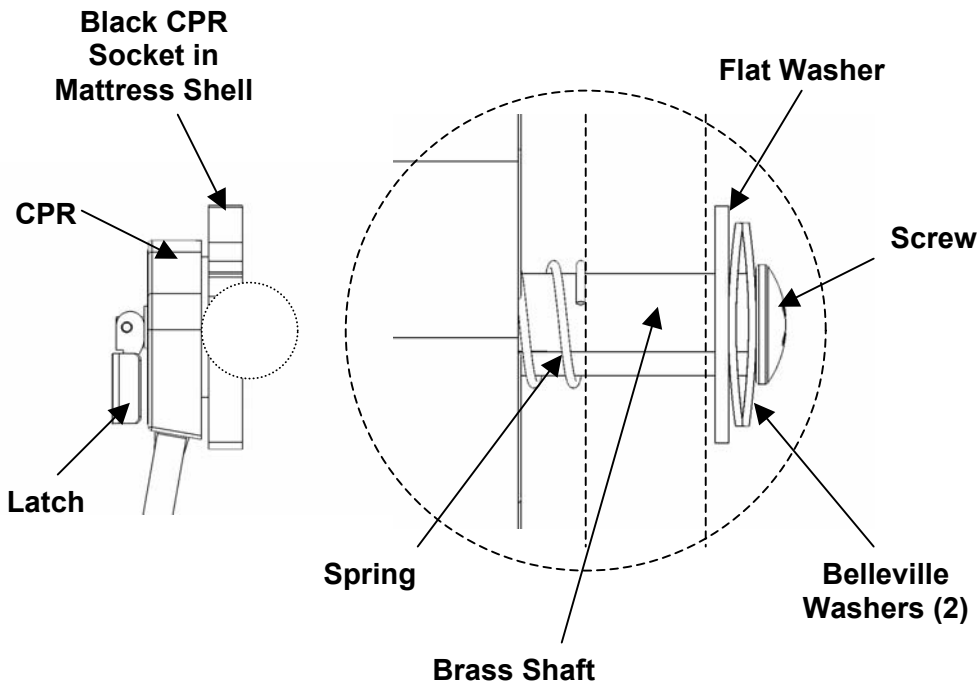

#### REMOVAL

1. Remove screw in the end of the brass shaft.
2. Remove two (2) Belleville washers.
3. Remove flat washer.
4. Slide CPR assembly out of the CPR socket.
5. Remove the spring.

#### INSTALLATION

1. Place Spring on the brass shaft of the CPR.
2. Slide brass shaft through the hole in the CPR socket.
3. With latch in open position, align two holes in CPR block with two screws (with spacers) on CPR socket.
4. Squeeze CPR block and socket together and place the flat washer onto the brass shaft.
5. Place the two (2) Belleville washers onto the brass shaft, as noted.

**IMPORTANT!** Make sure the two (2) Belleville washers are oriented so that when they are together they form a “pocket”.

6. Thread the screw into the end of the brass shaft. Tighten ensuring that the washers are centered on the brass shaft and head of screw contacts brass shaft.

## 5.0 MAINTENANCE AND CLEANING –

**IMPORTANT!** All disinfection should be done with a "hospital-grade" disinfectant registered with the Environmental Protection Agency (EPA) and in accordance with the manufacturer's specified instructions. Check manufacturer's instructions before use.

### 5.1 Electrical Controller:

The electronic controller is easy to maintain:

#### 5.1.1 Fuse Replacement:

**CAUTION!** Only use *UL-Approved* fuses that have the same rating as specified (See **Section 7.0**). Using fuses with higher ratings could result in damage and/or injury.

One (1) replacement fuse is provided with your controller and is located in the compartment on the electrical cord socket. To replace a fuse:

1. Ensure the power switch is in the OFF position.
2. Remove the power cord from the electrical socket on the side of the controller.
3. Using a small sized flat-head screwdriver, pry the fuse holder away from the socket and slide it out of the socket.
4. Remove the "blown" fuse from the fuse holder clip and discard.
5. Remove the spare fuse from the storage compartment and install it into the fuse holder clip (See Diagram Below):

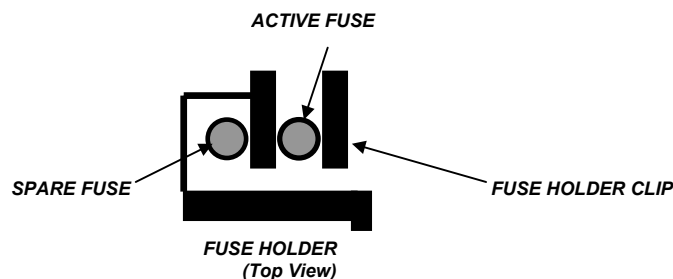

6. Push the fuse holder completely back into the electrical socket it until it "snaps" into place.

**NOTE:** The fuse holder must be properly oriented to slide in correctly. Do not force!

7. Replace power cord and turn on the controller.

#### 5.1.2 Filter Maintenance:

1. Unplug the electronic controller.
2. On the bottom of the unit, there are two (2) filter housings:
  - White – Air Intake Filter
  - Black – Cooling Fan Filter
3. Remove the filter grill covers and remove the filters. **DO NOT** unscrew the filter assembly.

### 5.1.2 Filter Maintenance (Continued):

4. Clean the filters by washing in a mild detergent and allow to air dry.
5. Insert the filters into the filter housing and replace the grill covers.
6. If the filters cannot be cleaned, or become damaged, contact SenTech Customer Service for replacement filters.

**IMPORTANT!** Good filter maintenance is critical in keeping your STGAE IV controllers in optimal operating condition. Failure to keep the filters clean will result in system downtime and increased repair costs

- 5.1.3 The exterior of the controller and CPR assembly should be periodically wiped down with cloth dampened with disinfectant.

**CAUTION!** DO NOT spray disinfectant directly on the electrical controller, or immerse the controller in any type of liquid. This could result in a severe electrical hazard.

- 5.1.4 Before plugging in the controller, check the power cord for electrical hazards, e.g., cuts, exposed wires, worn insulation, etc. If hazards are present, take the controller out of operation immediately and contact SenTech Customer Service

- 5.1.5 To ensure optimal performance of your MILLENNIUM system, calibration should be verified every 12 months. Contact SenTech Customer Service for calibration information.

## 5.2 Coverlet:

### 5.2.1 Washing and Disinfecting

*If there are visible signs of body fluids and/or substances present, coverlets should be washed between patients. Coverlets can be machine-washed using chlorine bleach (50-150ppm) or an *intermediate level* disinfectant, such as ProTech<sup>1</sup>. Bleach and disinfectant should be used according to the manufacturer's instructions. To determine the amount of bleach or disinfectant to use, determine the amount of water in the washer and then follow the *manufacturer's dilution instructions*. Soak the coverlet in the disinfectant or bleach during the wash cycle. Rinse thoroughly in clean water and dry before use.*

**NOTE!** 2.5 ounces of bleach per 10 gallons of water is approximately 100ppm of available chlorine.

**CAUTION!** DO NOT dry the coverlet using the “*heat*” cycle. Air-dry, or select a low or “*non-heat*” dry cycle, e.g., air fluff.

1. ProTech<sup>®</sup> is a tuberculocidal disinfectant cleaner and a registered trademark of Central Solutions, Inc.

### **5.2.2 Washing Alternative**

*If there are no visible signs of body fluids and/or substances present, the coverlet can be sanitized between patients. To sanitize the coverlet:*

1. Apply chlorine bleach, or an intermediate level disinfectant at the appropriate dilution (See **Section 5.2.1**) to the upper surface of the coverlet. Bleach/disinfectant may be applied either by spraying or by hand application.
2. Ensure surface is completely covered with the bleach/disinfectant.
3. Allow bleach/disinfectant to remain in contact with the surface according to the manufacturer's instructions.
4. Remove bleach/disinfectant and rinse.
5. Allow to air dry before use.

### **5.3 Outside Shell:**

Wipe down with disinfectant, ensuring that all surfaces come in contact with the disinfectant. Rinse off with a clean damp cloth and allow to air dry.

### **5.4 Air Cell Assembly:**

**CAUTION!** DO NOT machine wash or dry the air cells.

The air cell assembly does not routinely need to be cleaned or disinfected between patients. If cleaning/disinfection is required, follow the instructions in **Section 5.2.2** above.

### **5.5 Foam Mattress:**

The foam mattress is fully enclosed in a nylon-urethane cover and should not require cleaning. However, if it does become “visibly” soiled, it may be wiped down with disinfectant, ensuring that all surfaces come in contact with the disinfectant. Wipe off with a clean damp cloth and allow to air dry

### **5.6 CPR:**

The exterior of the CPR can be periodically wiped using a cloth dampened with disinfectant.

## 6.0 TROUBLESHOOTING –

Problem	Cause	Solution
<p>1. Alarm light is on.</p>	<p>The alarm is activated if the air cells do not reach programmed pressure in less than or equal to 20 minutes. This is usually an indication of an air leak in the system.</p>	<p>a) Check the CPR connections:</p> <p>For the <b>Standard CPR</b>, make sure the CPR plugs are fully inserted into the hoses (Stage IV 2000 = 2 hoses / Stage IV 3000 = 4 hoses).</p> <p>For the <b>Hospital Grade CPR</b>, see <b>Section 4.4.4</b>.</p> <p>b) Be sure all hoses are properly connected to the controller.</p> <p>c) Check all hoses along the inside of the mattress. Each hose should be tightly connected.</p> <p>d) Check each air cell to ensure there are no leaks. (It will be easier to detect a possible leak if you place the system in the MAX INFLATE mode.)</p> <p>e) Once the leak has been resolved, the alarm light will automatically turn off after three cycles. To reset the system more quickly, turn the power off and then on again to reset.</p>
<p>2. Patient is sinking or “bottoming out” while lying flat.</p>	<p>The pressures may be set too low for the patient’s weight.</p>	<p>Increase bed pressure. An increase of 3-5 mmHg is usually sufficient. However, wait at least one (1) full cycle before determining if the pressure increase was sufficient</p>

## 6.0 TROUBLESHOOTING GUIDE (Continued) –

<b>Problem</b>	<b>Cause</b>	<b>Solution</b>
3. The height and weight settings appear to be reversed.	The units of measure, i.e., English or metric, may be selected incorrectly.	Select proper units of measure by pressing the ENGLISH/METRIC key and re-enter patient weight and height, if needed.
4. The pressure setting was increased, but the pressure does not appear changed.	The AUTOSET key may have been pressed by mistake which would “overwrite” all customized settings.	Re-enter pressures needed. DO NOT press AUTO SET.
5. Air is not constantly flowing into the Low Air Loss Coverlet	The internal pump gives priority to the air cells in the mattress. Once the air cells are inflated to the selected pressure, air will then be directed to the coverlet.	Allow air cells to pressurize.
6. Display readings appear “scrambled”.	Power surges can cause the controller to temporarily malfunction.	Turn the controller off for five (5) seconds and then on again to reset.
7. Display readings appear abnormally high	May be caused by crimped or pinched hoses, which cause an uneven delivery of air.	Check all hoses and eliminate any restrictions, e.g., sharp bends, crimps, folds, etc.
8. Patient is “bottoming out” when in the sitting or inclined position.	Pressure is concentrated in the trunk region	Activate the FOWLER BOOST to increase pressure by 20%.

## 6.0 TROUBLESHOOTING GUIDE (Continued) –

Problem	Cause	Solution
9. Air controller is inoperable	May be caused by a power surge  Or  May be caused by internal damage	If the power switch does <u>not</u> illuminate when the power is turned on, check the fuse(s) located in the compartment on the electrical cord socket and replace if necessary (See Section 7.0 for fuse information and ratings).  If this does not correct the problem, contact SenTech Customer Service at <b>800-474-4225</b> for Repair & Service information
10. Controller sounds like it is working, but no air is coming out.	Dirt has clogged the valves due to improper filter maintenance.	Contact SenTech Customer Service at <b>800-474-4225</b> for Repair & Service information.

## 7.0 PRODUCT SPECIFICATIONS –

Product Specifications for your STAGE IV SYSTEMS are presented below:

### Electronic Controller –

#### Physical Dimensions:

Height (Inches)	12.1
Width (Inches)	14.5
Depth (Inches)	6.0
Weight (Pounds)	21

#### Electrical Parameters:

##### US and Canada:

UL2601 Classification

Class I

Type B   
120VAC, 60Hz

Power Requirements

Fuse\*

3.15A, 250V, Fast  
Acting (*UL-Approved*)

Maximum Current

< 1.0A

Ground

Protective Earth 

##### Europe:

Power Requirements

240VAC, 50Hz

Fuse

1A, 250V, Fast Acting

Maximum Current

< 0.5A

#### Operating Parameters:

Weight Range (Pounds):

50-500  
80-990 (3000 Plus)

Height Range (Inches)

46-78

Pressure Range (mmHg)

5-50 (Bed)  
40-95 (Chair)

\* One (1) replacement fuse is provided with your controller and is located in the compartment on the electrical cord socket).

**CAUTION! Only use fuses that have the same rating as specified above. Using fuses with higher ratings could result in damage and/or injury.**

#### Environmental Conditions:

##### Operating Conditions:

Ambient Temperature (°C)

+10 to +40

Relative Humidity (%)

30 to 75

Atmospheric Pressure (hPa)

700 to 1060

##### Storage/Shipping Conditions:

Ambient Temperature (°C)

-20 to +70

Relative Humidity (%)

10 to 100

Atmospheric Pressure (hPa)

500 to 1060



## 7.0 PRODUCT SPECIFICATIONS (Continued) –

### Mattress Replacement (Fully-Inflated) – Physical Dimensions

Height (Inches)	8.5
Width (Inches):	36
	Multiple Widths (3000 PLUS)
Length (Inches)	80
Weight (Pounds):	22 (STAGE IV 2000)
	24 (STAGE IV 3000)
	26-30 (3000 PLUS)

## 8.0 WARRANTY INFORMATION -

### **LIMITED WARRANTY**

SenTech Medical Systems, Inc. ("SenTech") warrants each of its products to perform in accordance with established specifications for the following time periods, starting from date the product was shipped from the SenTech facility.

#### **Stage IV & Millennium Systems**

**Compressor Pump: 3 Years**

**Electronic Controller: 2 Years**

**Soft Goods: 1 Year**

#### **Primary Care, Sentry, Express & Air Chair Systems**

**Compressor Pump: 2 Years**

**Electronic Controller: 1 Year**

**Soft Goods: 1 Year**

**Battery: 6 Months**

**Recliner Chair: 2 Years**

During the warranty period, SenTech will repair or replace at no charge any products that are not performing in accordance with established specifications, unless the problem/failure is due to (1) customer damage, negligence and/or misuse or (2) unauthorized repairs. Items not covered under warranty include, but are not limited to: stains, punctures, cuts, damages to electrical cords, rips or tears, dents and/or lost/missing parts.

All products returned for warranty repairs must be assigned a return authorization number, prior to return. Returns should include information describing the problem and/or requested repair and be sent to SenTech by prepaid transportation. SenTech will return the repaired/replaced product at no charge. Warranty repairs do not extend the length of the warranty period. During the warranty period, SenTech will provide one Bio-Med test at no charge, excluding shipping/handling.

Neither SenTech, its officers, directors, employees or agents shall be liable for consequential or other damages, including but not limited to personal injury, loss, or any other expense, directly or indirectly arising from the use of its products. The sole remedy for breach of the limited warranty granted herein shall be repair or replacement of the SenTech products.

All product specifications are subject to change without notice.

## **9.0 PRODUCT RETURN –**

The STAGE IV SYSTEMS have been designed to provide you with years of trouble-free service. However, in the event that the product needs to be returned for any reason, such as calibration or repair, the following return procedure must be followed. Failure to follow this procedure may result in unnecessary delays.

### **Return Procedure -**

Before returning a product to SenTech:

1. Contact Customer Service and obtain a **Return Material Authorization (RMA)** number.
2. Package the product in its “approved” packaging.
3. Reference RMA number on the shipping container and shipping documents.
4. Ship product to the attention of Customer Service at the following address:

***SenTech Medical Systems, Inc.  
4200 NW 120 Avenue  
Coral Springs, FL 33065***

***SenTech Medical Systems, Inc.***

*4200 NW 120 Avenue  
Coral Springs, FL 33065*

*Phone: 954-340-0500*

*FAX: 954-340-0511*

*Web Site: [www.sentechmedical.com](http://www.sentechmedical.com)*

*STAGE IV is a registered trademark  
of SenTech Medical Systems, Inc.  
Coral Springs, FL*